



**RU-200, RU-500  
FC-200 and FC-500  
Refrigerated units  
USER'S MANUAL**

The logo for Tequipment.NET, featuring a large red "T" on the left. To its right is a small American flag with the word "USA" above it. Below the flag, the word "Tequipment" is written in blue, and ".NET" is written in red below it. A blue line connects the bottom of the "T" to the bottom of ".NET".	<p><b>205 Westwood Ave Long Branch, NJ 07740 1-877-742-TEST (8378) Fax: (732) 222-7088 salesteam@Tequipment.NET</b></p>
--	---

Issue 10.  
Date of issue:  
23rd July 2003  
® Techne is the trademark  
of Techne and Techne Inc.  
© Techne, 2003



**CONTENTS****Refrigerated units User's Manual**

	page
<b>SAFETY AND INSTALLATION</b>	
Declaration of conformity	3
English	4
Français	5
Deutsch	6
Español	7
<b>INTRODUCTION</b>	8
Dip Coolers	8
Flow Coolers	9
Operator Safety	9
Specification	10
Siting Considerations	11
Setting up the unit	11
Carrying a Dip Cooler	14
Cleaning your unit	14
Packing	14
<b>OPERATION</b>	15
Precautionary Measures	15
Operating your unit	15
Daily Maintenance	16
Fault Finding	16
Service	17
<b>ADDITIONAL INFORMATION</b>	18
General Advice	18
General Fault finding	18
Accessories	18

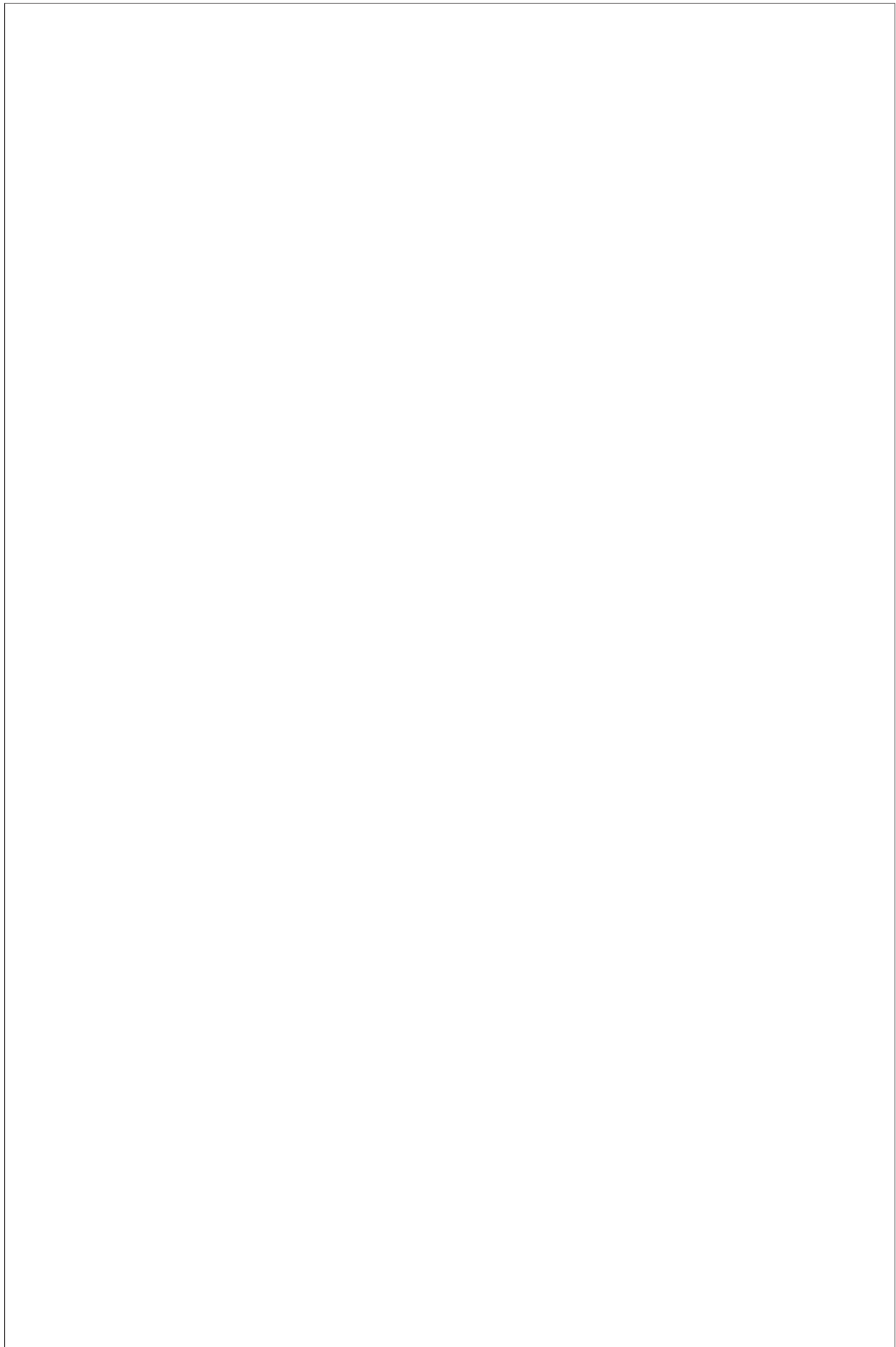



Techne  
 Ickleton Road  
 Duxford  
 Cambridge  
 CB2 4PZ



## Declaration of Conformity

Techne Units RU-200, RU-500, FC-200 and FC-500 have been designed to comply with the following European Standards:

EN 50081-1:1992 Electromagnetic Compatibility; Generic emission standard.

EN 50082-1:1992 Electromagnetic Compatibility; Generic immunity standard (Performance criterion B).

EN 61010-1:1993 Safety requirements for electrical equipment for measurement, control and laboratory use.

EN 61010-2-010:1995 Particular requirements for laboratory equipment for the heating of materials.

I have made all reasonable enquiries regarding the unit stated and its conformance to the following EU directives:

Low Voltage directive, 73/23/EEC and amendment 93/68/EEC, and

EMC Directive 89/336/EEC and amendments 91/263/EEC 92/31/EEC and 93/68/EEC.

To the best of my knowledge and belief these units conform to these directives.

This Declaration is controlled under an ISO 9001:2000 system certificated by BSI Quality Assurance, certificate number FM13585.

Signature

Name

B C Coombes

Position

Quality Manager

**Introduction**

Please read all the information in this booklet before using the unit.

**Warning**

HIGH TEMPERATURES ARE DANGEROUS: they can cause serious burns to operators and ignite combustible material. Techne have taken great care in the design of these units to protect operators from hazards, but users should pay attention to the following points:

- USE CARE AND WEAR PROTECTIVE GLOVES TO PROTECT HANDS;
- DO NOT put hot objects on or near combustible objects;
- DO NOT operate the unit close to inflammable liquids or gases;
- DO NOT place any liquid directly in your unit;
- At all times USE COMMON SENSE.

**Operator Safety**

All users of Techne equipment must have available the relevant literature needed to ensure their safety. It is important that only suitably trained personnel operate this equipment, in accordance with the instructions contained in this manual and with general safety standards and procedures. If the equipment is used in a manner not specified by Techne the protection provided by the equipment to the user may be impaired. All Techne units have been designed to conform to international safety requirements and are fitted with an overtemperature cutout. On some models, the cutout is adjustable and should be set to suit the application. On all other models the cutout is preset to protect the unit. If a safety problem should be encountered, switch off at the mains socket and remove the plug from the supply.

**Installation**

1. All Techne units are supplied with a power cable. This may be integral or plug-in.
2. Before connecting the mains supply, check the voltage against the rating plate. Connect the mains cable to a suitable plug according to the table below. **Note that the unit must be earthed to ensure proper electrical safety.**

<i>Connections</i>	<i>220/240V</i>	<i>110/120V</i>
Live	Brown	Black
Neutral	Blue	White
Earth	Green/yellow	Green

The fused plug supplied with the mains lead for use in the UK is fitted with the following value fuse to protect the cable:

230V UK      13 AMP

The fuse in the unit protects the unit and the operator. Note that units marked 230V on the rating plate work at 220V; units marked 120V work at 110V. In both cases, however, the heating rate will degrade by approximately 8%. The rating plate is on the rear of the unit.

3. Plug the mains cable into the socket on the rear of the unit.
4. Place the unit on a suitable bench or flat workspace, or in a fume cupboard if required, ensuring that the air inlet vents on the underside are free from obstruction.
5. Symbols on or near the power switch of the unit have the following meanings:

I	: mains switch On
O	: mains switch Off

**After use**

When you have finished heating samples, remember that parts of the unit – the tubes, blocks and associated accessories – may be very hot. Take the precautions listed earlier.

**Guarantee**

The unit is guaranteed against any defect in material or workmanship for the period specified on the enclosed guarantee card. This period is from the date of purchase, and within this period all defective parts will be replaced free of charge provided that the defect is not the result of misuse, accident or negligence. Servicing under this guarantee should be obtained from the supplier.

Notwithstanding the description and specification(s) of the units contained in the Operator's Manual, Techne hereby reserves the right to make such changes as it sees fit to the units or to any component of the units.

This Manual has been prepared solely for the convenience of Techne customers and nothing in this Instruction Book shall be taken as a warranty, condition or representation concerning the description, merchantability, fitness for purpose or otherwise of the units or components.

**User maintenance**

NOTE THAT THIS EQUIPMENT SHOULD ONLY BE DISMANTLED BY PROPERLY TRAINED PERSONNEL. REMOVING THE SIDE, FRONT OR REAR PANELS EXPOSES POTENTIALLY LETHAL MAINS VOLTAGES. THERE ARE NO USER MAINTAINABLE PARTS WITHIN THE EQUIPMENT.

In the unlikely event that you experience any problems with your unit which cannot easily be remedied, you should contact your supplier and return the unit if necessary. Please include any details of the fault observed and remember to return the unit in its original packing. Techne accept no responsibility for damage to units which are not properly packed for shipping: if in doubt, contact your supplier. See the Decontamination Certificate supplied with your unit.

1. **Cleaning**

Before cleaning your unit ALWAYS disconnect from the power supply and allow to cool below 50° C. Your unit can be cleaned by wiping with a damp soapy cloth. Care should be exercised to prevent water from running inside the unit. Do not use abrasive cleaners.

2. **Fuses**

Your unit is protected by one or two fuses. These should only be changed by suitably qualified personnel. If the fuses blow persistently, a serious fault is indicated and you may need to return the unit to your supplier for repair.

**Contact Information**

For technical, sales or servicing information, contact your local Techne dealer or,

Techne, Duxford,  
Cambridge, CB2 4PZ, United Kingdom.

Telephone: +44(0)1223 832401  
Fax: +44(0)1223 836838  
Service: +44(0)1223 836950 Out of office hours  
e-mail: sales@techne.com  
Web site: www.techne.com

or,

Techne Inc, 3 Terri Lane,  
Suite 10, Burlington,  
New Jersey 08016, USA.

Telephone: 609-589-2560  
Toll free: 800-225-9243 ext 306  
Fax: 609-589-2571  
e-mail: labproducts@techneusa.com  
Web site: www.techneusa.com

## Introduction

Veillez lire attentivement toutes les instructions de ce document avant d'utiliser l'appareil.

## Avertissement

**DANGER DE TEMPERATURES ELEVEES** : les opérateurs peuvent subir de graves brûlures et les matériaux combustibles risquent de prendre feu.

Techne a apporté un soin tout particulier à la conception de ces appareils de façon à assurer une protection maximale des opérateurs, mais il est recommandé aux utilisateurs de porter une attention spéciale aux points suivants :

- **PROCEDER AVEC SOIN ET PORTER DES GANTS POUR SE PROTEGER LES MAINS.**
- **NE PAS** poser d'objets chauds sur ou près de matériaux combustibles.
- **NE PAS** utiliser l'appareil à proximité de liquides ou de gaz inflammables.
- **NE PAS** verser de liquide directement dans l'appareil.
- **FAIRE TOUJOURS PREUVE DE BON SENS.**

## Sécurité de l'opérateur

Tous les utilisateurs de produits Techne doivent avoir pris connaissance des manuels et instructions nécessaires à la garantie de leur sécurité.

Important : cet appareil doit impérativement être manipulé par un personnel qualifié et utilisé selon les instructions données dans ce document, en accord avec les normes et procédures de sécurité générales. Dans le cas où cet appareil ne serait pas utilisé selon les consignes précisées par Techne, la protection pour l'utilisateur ne serait alors plus garantie.

Tous les appareils Techne sont conçus pour répondre aux normes de sécurité internationales et sont dotés d'un coupe-circuit en cas d'excès de température. Sur certains modèles, ce coupe-circuit est réglable pour s'adapter à l'application désirée. Sur d'autres modèles, il est pré-réglée en usine pour assurer la protection de l'appareil.

Dans le cas d'un problème de sécurité, coupez l'alimentation électrique au niveau de la prise murale et enlevez la prise connectée à l'appareil.

## Installation

1. Tous les appareils Techne sont livrés avec un câble d'alimentation qui peut être intégré à l'appareil ou à raccorder.
2. Avant de brancher l'appareil, vérifiez la tension requise indiquée sur la plaque d'identification. Raccordez le câble électrique à la prise appropriée en vous reportant au tableau ci-dessous. **Il est important que l'appareil soit relié à la terre pour assurer la protection électrique requise.**

Connexions	220/240 V	110/120 V
Phase	Marron	Noir
Neutre	Blue	Blanc
Terre	Vert/juane	Vert

Le fusible à l'intérieur de l'appareil est destiné à assurer la protection de l'appareil et de l'opérateur.

**Remarque** : les appareils dont la plaque indique 230 V peuvent fonctionner sur 220 V, et ceux dont la plaque indique 120 V peuvent fonctionner sur 110 V. Dans les deux cas cependant, le capacité de chauffage diminuera d'environ 8 %. La plaque d'identification se trouve à l'arrière de l'appareil.

3. Raccordez le câble d'alimentation à la prise située à l'arrière de l'appareil.
4. Placez l'appareil sur un plan de travail ou surface plane, ou le cas échéant, dans une hotte d'aspiration, en s'assurant que les trous d'aération situés sous l'appareil ne sont pas obstrués.
5. Les symboles situés sur ou à côté de l'interrupteur de l'appareil ont la signification suivante :
  - : arrêt
  - I : marche

## Après utilisation

Lorsque vous avez fini de chauffer les échantillons, n'oubliez pas que certaines parties de l'appareil - les éprouvettes, leurs supports et autres accessoires - risquent d'être très chaudes. Il est donc recommandé de toujours prendre les précautions citées plus haut.

## Garantie

L'appareil est garanti contre tout défaut ou vice de fabrication pour la durée figurant sur la carte de garantie, à compter de la date d'achat de l'appareil. Au cours de cette période, toutes les pièces défectueuses seront remplacées gratuitement, dans la mesure où la défaillance n'est pas due à une mauvaise utilisation, un accident ou une négligence. Toute réparation sous garantie sera effectuée par le fournisseur.

Malgré la description et les spécifications de l'appareil données dans le manuel de l'utilisateur, Techne (Cambridge) Limited se réserve le droit d'effectuer les changements nécessaires à l'appareil ou à tout élément qui entre dans sa composition.

Ce manuel a été exclusivement rédigé à l'attention des clients de Techne (Cambridge) Limited, et aucun élément de ce guide d'instructions ne peut être utilisé comme garantie, condition ou représentation concernant la description, commercialisation, adaptation aux conditions d'utilisation ou autre des appareils ou de leurs composants.

## Entretien utilisateur

**IMPORTANT : CET APPAREIL NE PEUT ETRE DEMONTE QUE PAR DU PERSONNEL QUALIFIE.**

**LORSQUE LES PANNEAUX AVANT, ARRIERE ET LATERAUX SONT DEMONTES, L'OPERATEUR EST EXPOSE A DES TENSIONS QUI PEUVENT ETRE MORTELLES.**

**CET APPAREIL NE CONTIENT AUCUN ELEMENT QUI DEMANDE UN ENTRETIEN DE LA PART DE L'UTILISATEUR.**

Dans le cas peu probable où votre appareil présente un défaut de fonctionnement auquel il est difficile de remédier, il est alors préférable de contacter votre fournisseur et, le cas échéant, de renvoyer le matériel. Veuillez inclure une description détaillée du problème constaté et retourner l'appareil dans son emballage d'origine. Techne ne sera pas tenu responsable des dommages subis par tout appareil dont l'emballage est inadéquat pour le transport. Pour plus de sûreté, contactez votre fournisseur. Voir le certificat de décontamination livré avec le produit.

### 1. Nettoyage

Avant de nettoyer l'appareil, assurez-vous TOUJOURS que le câble d'alimentation est déconnecté et laissez la température redescendre en dessous de 50 °C.

Utilisez un chiffon imprégné d'eau savonneuse pour nettoyer l'appareil. Veillez à ne pas introduire d'eau dans l'appareil. N'utilisez pas de produits abrasifs.

### 2. Fusibles

La protection de l'appareil est assurée par un ou deux fusibles dont le remplacement ne peut être effectué que par un personnel qualifié.

Si les fusibles sautent sans arrêt, il s'agit d'un problème sérieux. Nous vous conseillons dans ce cas de prendre contact avec votre fournisseur pour réparation.

**Einleitung**

Bitte lesen Sie diese Bedienungsanleitung komplett bevor Sie dieses Gerät benutzen.

**Warnung**

HOHE TEMPERATUREN SIND GEFÄHRLICH: sie können dem Bediener ernsthafte Verletzungen zufügen und brennbare Materialien können sich leicht entzünden.

Techne hat bei der Konstruktion dieses Gerätes sehr darauf geachtet, daß der Bediener vor Gefahren geschützt ist. Dennoch sollten Sie auf die folgenden Punkte achten:

- SEIEN SIE VORSICHTIG UND TRAGEN SIE SCHUTZHANDSCHUHE
- Legen Sie heiße Gegenstände NICHT auf oder in die Nähe von leicht brennbaren Materialien; vermeiden Sie Arbeiten in der Nähe von leicht entzündbaren Flüssigkeiten oder Gasen.
- Bringen sie KEINE Flüssigkeiten direkt in Ihr Gerät.
- Benutzen Sie immer den normalen Menschenverstand

**Sicherheit des Anwenders**

Alle Benutzer von Techne Geräten müssen Zugang zu der entsprechenden Literatur haben, um ihre Sicherheit zu gewähren.

Es ist wichtig, daß diese Geräte nur von entsprechend geschultem Personal betrieben werden, das die in dieser Gebrauchsanweisung enthaltenen Maßnahmen und allgemeine Sicherheitsbestimmungen und -vorkehrungen beachtet. Wenn das Gerät anders eingesetzt wird als vom Hersteller empfohlen, kann dies die persönliche Sicherheit des Anwenders beeinträchtigen. Die Geräte von Techne entsprechen den internationalen Sicherheitsbestimmungen und sind mit einem automatischen Übertemperaturabschalter ausgestattet. Bei einigen Modellen ist der Übertemperaturabschalter verstellbar und sollte je nach Anwendung entsprechend eingestellt werden. Bei allen anderen Modellen ist der Temperaturschutz voreingestellt um Schäden am Gerät zu vermeiden. Wenn ein Sicherheitsproblem auftreten sollte, muß das Gerät ausgeschaltet und vom Stromnetz getrennt werden.

**Installation**

1. Alle Techne Geräte werden mit einem Stromanschlußkabel geliefert. Dieses ist entweder fest mit dem Gerät verbunden oder zum Einstecken.
2. Vergleichen Sie, ob die Spannung Ihrer Stromversorgung mit den Angaben auf dem Typenschild des Gerätes übereinstimmen. Verbinden Sie das Stromanschlußkabel mit einer geeigneten Stromversorgung gemäß der nächstehenden Tabelle. Achtung: Das Gerät muß geerdet sein, um die elektrische Sicherheit zu gewährleisten!

Verbindungen	220/240V	110/120V
Stromführend	Braun	Schwarz
Neutral	Blau	Weiß
Erde	Grün/Gelb	Grün

Geräte, die für 230 Volt ausgelegt sind, können auch bei 220 Volt arbeiten, Geräte für 120 Volt auch bei 110 Volt. In beiden Fällen verringert sich die Aufheizrate um ca. 8%. Das Typenschild befindet sich hinten am Gerät.

3. Stecken Sie das Stromkabel in die vorgesehene Buchse hinten am Gerät.
4. Stellen Sie das Gerät auf eine ebene Arbeitsfläche bzw. (falls erforderlich) unter einen Laborabzug. Beachten Sie, daß die Entlüftungsrippen an der Geräteunterseite immer frei zugänglich sind.
5. Die Symbole auf oder neben dem EIN/AUS-Schalter an der Geräterückseite bedeuten:

I	: An
O	: Aus

**Nach dem Gebrauch**

Vergessen Sie nicht, daß Teile des Gerätes (die Gefäße, die Blöcke und andere Zubehörteile) nach dem Erhitzen von Proben noch sehr heiß sein können. Bitte beachten Sie die oben genannten Vorsichtsmaßnahmen.

**Garantie**

Die Garantiedauer des Gerätes ist auf der beiliegenden Garantiekarte angegeben und schließt Fehler im Material oder der Verarbeitung ein. Die Garantiedauer beginnt am Tag des Einkaufs. Sämtliche defekte Teile werden innerhalb dieses Zeitraumes kostenlos ersetzt unter der Voraussetzung, daß dem Defekt keine unsachgemäße Handhabung, Fahrlässigkeit oder ein Unfall zugrundeliegt. Der unter diese Garantie fallende Service wird vom Lieferanten geleistet.

Ungeachtet der in dieser Gebrauchsanweisung enthaltenen Beschreibungen und Spezifikationen, behält sich Techne hiermit das Recht vor, Änderungen an den Geräten bzw. an einzelnen Geräteteilen durchzuführen.

Diese Gebrauchsanleitung wurde ausschließlich dazu erstellt, um Kunden die Handhabung der Techne-Geräte zu erleichtern. Nichts in dieser Gebrauchsanleitung darf als Garantie, Bedingung oder Voraussetzung verstanden werden, sei es die Beschreibung, Marktgängigkeit, Zweckdienlichkeit oder sonstiges bezüglich der Geräte oder deren Bestandteile.

**Wartung durch den Bediener**

BEACHTEN SIE, DASS DIESES GERÄT NUR VON TECHNISCHEN FACHKRÄFTEN GEÖFFNET UND DEMONTIERT WERDEN DARF.

DURCH ENTFERNEN DES GEHÄUSES ODER GEHÄUSETEILEN SIND BAUTEILE MIT LEBENGEFÄHRLICHEN SPANNUNGEN FREI ZUGÄNGLICH.

IM INNERN DES GERÄTES BEFINDEN SICH KEINE TEILE, DIE VOM ANWENDER GEWARTET WERDEN MÜSSEN.

Falls Ihr Gerät nicht ordnungsgemäß arbeitet, wenden Sie sich an Ihren Lieferanten oder senden Sie das Gerät wenn nötig zurück. Fügen Sie eine genaue Beschreibung des Defektes bei. Verpacken Sie das Gerät möglichst im Originalkarton. Bitte beachten Sie, daß Techne und thermODUX keine Haftung bei Transportschäden aufgrund unzureichender Verpackung übernehmen. Setzen Sie sich im Zweifelsfall mit Ihrem Lieferanten in Verbindung. Bitte beachten Sie die Entgiftungsbescheinigung, die Sie mit dem Gerät erhalten haben.

**1. Reinigen**

Bevor Sie Ihr Gerät reinigen, sollten Sie

- zuerst den Netzstecker ziehen
- das Gerät unter 50°C abkühlen lassen.

Ein feuchtes Tuch mit Seifenlösung reinigt Ihr Gerät am besten. Achten Sie darauf, daß kein Wasser in das Gerät gelangt. Verwenden Sie keine Scheuermittel.

**2. Sicherungen**

Die Stromzuleitung ist durch ein oder zwei Sicherungen geschützt. Diese sollten nur durch qualifiziertes Fachpersonal ausgetauscht werden. Wenn die Sicherung wiederholt durchbrennt, liegt ein größerer Defekt vor. Das Gerät muß zur Reparatur an Ihren Lieferanten eingesandt werden.



## Introducción

Le rogamos lea cuidadosamente la información contenida en este folleto antes de manipular el aparato.

## Aviso

LAS TEMPERATURAS ELEVADAS SON PELIGROSAS: pueden causarle graves quemaduras y provocar fuego en materiales combustibles.

Techne ha puesto gran cuidado en el diseño de estos aparatos para proteger al usuario de cualquier peligro; aún así se deberá prestar atención a los siguientes puntos:

- EXTREME LAS PRECAUCIONES Y UTILICE GUANTES PARA PROTEGERSE LAS MANOS;
- NO coloque objetos calientes encima o cerca de objetos combustibles;
- NO maneje el aparato cerca de líquidos inflamables o gases;
- NO introduzca ningún líquido directamente en el aparato;
- UTILICE EL SENTIDO COMUN en todo momento.

## Seguridad del usuario

Todos los usuarios de equipos Techne deben disponer de la información necesaria para asegurar su seguridad.

De acuerdo con las instrucciones contenidas en este manual y con las normas y procedimientos generales de seguridad, es muy importante que sólo personal debidamente capacitado opere estos aparatos. De no ser así, la protección que el equipo le proporciona al usuario puede verse reducida.

Todos los equipos Techne han sido diseñados para cumplir con los requisitos internacionales de seguridad y traen incorporados un sistema de desconexión en caso de sobretemperatura. En algunos modelos el sistema de desconexión es variable, lo que le permite elegir la temperatura según sus necesidades. En otros, el sistema de desconexión viene ya ajustado para evitar daños en el equipo.

En caso de que surgiera un problema de seguridad, desconecte el equipo de la red.

## Instalación

1. Todos los aparatos Techne se suministran con un cable de alimentación. Puede ser fijo o independiente del aparato.
2. Antes de conectarlo, compruebe que el voltaje corresponde al de la placa indicadora. Conecte el cable de alimentación a un enchufe adecuado según la tabla expuesta a continuación. El equipo debe estar conectado a tierra para garantizar la seguridad eléctrica.

Conexiones	220/240V	110/120V
Línea	Marrón	Negro
Neutro	Azul	Blanco
Tierra	Verde/amarillo	Verde

El fusible una vez instalado protege tanto al equipo como al usuario.

Asegúrese de que los equipos marcados 230V en la placa indicadora funcionan a 220V y de que los equipos marcados 120V funcionan a 110V. No obstante, en ambos casos la velocidad de calentamiento se verá reducida en un 8% aproximadamente. La placa indicadora está situada en la parte posterior del equipo.

3. Conecte el cable a la toma de tensión en la parte posterior del equipo.
4. Sitúe el aparato en un lugar apropiado tal como una superficie de trabajo plana, o si fuera necesario incluso en una campana con extractor de humos, asegurándose de que las entradas de aire en la parte inferior no queden obstruidas.
5. Los símbolos que se encuentran en o cerca del interruptor de alimentación tienen los siguientes significados:

- I : Interruptor principal encendido
- O : Interruptor principal apagado

## Después de su uso

Cuando haya finalizado el calentamiento de muestras, recuerde que las piezas del equipo, tales como tubos, bloques y demás accesorios, pueden estar muy calientes. Tome las precauciones mencionadas anteriormente.

## Garantía

Este aparato está garantizado contra cualquier defecto material o de fabricación durante el periodo especificado en la tarjeta de garantía adjunta. Este plazo inicia a partir de la fecha de compra, y dentro de este periodo todas las piezas defectuosas serán reemplazadas gratuitamente siempre que el defecto no sea resultado de un uso incorrecto, accidente o negligencia. Mientras se encuentre bajo garantía las revisiones las debe llevar a cabo el proveedor.

A pesar de la descripción y las especificaciones de los aparatos contenidas en el Manual del Usuario, Techne (Cambridge) Limited se reserva por medio de este documento el derecho a efectuar los cambios que estime oportunos tanto en los aparatos como en cualquier componente de los mismos.

Este manual ha sido preparado exclusivamente para los clientes de Techne (Cambridge) Limited y nada de lo especificado en este folleto de instrucciones se tomará como una garantía, condición o aseveración de la descripción, comerciabilidad o adecuación para cualquier fin específico de los aparatos o sus componentes.

## Mantenimiento

ESTE APARATO DEBE SER DESMONTADO SOLO Y EXCLUSIVAMENTE POR PERSONAL DEBIDAMENTE CAPACITADO.

EL RETIRAR LOS PANELES LATERALES, FRONTALES O TRASEROS SUPONE DEJAR AL DESCUBIERTO TENSION DE LA RED PELIGROSA.

EL EQUIPO NO CONSTA DE NINGUNA PIEZA DE CUYO MANTENIMIENTO SE PUEDA ENCARGAR EL USUARIO.

En el caso improbable de que experimentara algún problema con su aparato que no pudiera resolver con facilidad, debería ponerse en contacto con su proveedor y devolverlo si fuera necesario. Indique de forma detallada todos los defectos que haya notado y devuelva el equipo en su embalaje original. Techne no aceptará responsabilidad alguna por daños causados en equipos que no estuvieran debidamente embalados para su envío; si tuviera alguna duda, póngase en contacto con su proveedor. Sírvase consultar el Certificado de Descontaminación suministrado con su aparato.

### 1. Limpieza

Antes de limpiar su aparato, desconéctelo SIEMPRE de la fuente de alimentación y permita que se enfríe por debajo de los 50°C.

Este aparato se puede limpiar pasándole un paño húmedo enjabonado. Hágalo con cuidado para evitar que caiga agua dentro del mismo. No utilice limpiadores abrasivos.

### 2. Fusibles

Su aparato está protegido por uno o dos fusibles. Sólo deben cambiarlos personal debidamente capacitado.

Si los fusibles se fundieran repetidamente, esto indicaría una avería grave y puede que tuviera que devolverle el aparato a su proveedor para su reparación.

## INTRODUCTION

Read the whole of this book before commencing work with the unit.

The book applies to a range of Techne fridge units, Dip Coolers RU-200 and RU-500 and Flow Coolers FC-200 and FC-500. Hence paragraphs or sections without a heading or reference apply to all units while paragraphs or sections with headings apply to specific units. For Refrigerated Baths there is a separate booklet.

The Techne fridge units are designed to cool liquids to temperatures around ambient and below by extracting heat continuously. The temperature is controlled by a temperature controller with a heater adding heat as necessary. Depending upon the circuit and the application this could be a Techne Thermoregulator, TE-10 series or TU-20 series, or it could be a Techne Circulator, the C-85A or C-85D. Each unit, fridge or controller, has its particular application which should be considered when setting up a temperature controlled system.

## Dip Coolers

The RU-200 and RU-500 are designed to work with Techne laboratory baths and thermoregulators without reducing the working area of the bath. They consist of a refrigeration unit where the evaporation coil is on a flexible hose. The coil is placed in the liquid and heat is extracted as the coil cools. The Dip Coolers work most efficiently when the liquid flows over the coil.

The Dip Coolers are designed so that the cooling coil fits in the corner of a Techne bath supported by a special cover on the bridge piece. However they may be used in any bath but the flexible hose must not be allowed in the liquid.

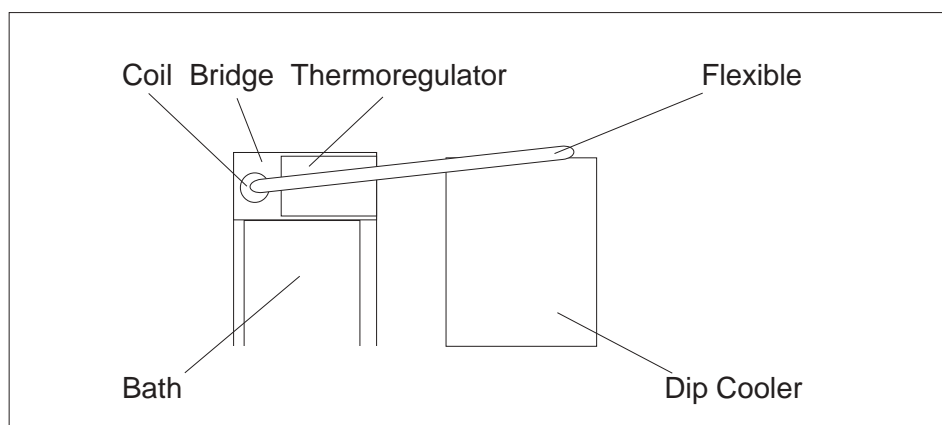

## Flow Coolers

The FC-200 and the FC-500 are designed to work with the Techne C-85 circulator to give the temperature control. They are normally used to give circulation round a closed loop system, but may also be used in the open tank situation where the use of a dip cooler is impractical.

The Flow Coolers use a refrigerant which is circulated through a compact heat exchanger which has inlet and outlet pipes for the working liquid on the rear of the unit. These pipes are 16mm diameter. The flow coolers need a minimum flow rate of 10 litres/min at 20°C to prevent freezing in the heat exchanger.

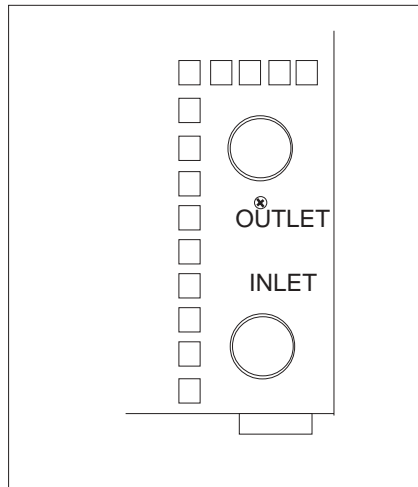

## Operator Safety

All users of Techne equipment must have available the relevant literature needed to ensure their safety.

It is important that only suitably trained personnel operate this equipment, in accordance with the instructions contained in this manual and with general safety standards and procedures.

Techne refrigerated units have been designed to conform to international safety requirements.

If there is any doubt relating to the proper use of this equipment, the staff at Techne will be pleased to assist you.

## Specification

The minimum temperatures quoted in the specification are achieved in an ambient of 20 °C with the appropriate liquid in a well insulated 8 litre bath. However many things will affect the minimum obtainable temperature, such as: ambient temperature, insulation and length of circulation system, condition of the working liquid, heat input and so on.

<b>DIP COOLERS</b>	<b>RU-200</b>	<b>RU-500</b>
Minimum temperature	-20 °C	-35 °C
Cooling capacity at:		
20 °C	145 W	240 W
0 °C	145 W	240 W
-10 °C	110 W	230 W
Nominal dimensions and weights		
Overall:		
Length	420 mm	430 mm
Width	235 mm	370 mm
Height	300 mm	325 mm
Coil:		
Length	85 mm	85 mm
Diameter	75 mm	75 mm
Hose length to coil	1250 mm	1250 mm
Net Weight	19 kg	39 kg
<b>FLOW COOLERS</b>	<b>FC-200</b>	<b>FC-500</b>
Minimum temperature	-20 °C	-35 °C
Cooling capacity at:		
20 °C	140 W	210 W
0 °C	140 W	210 W
-10 °C	110 W	200 W
Nominal dimensions and weights		
Overall:		
Length	420 mm	430 mm
Width	235 mm	370 mm
Height	300 mm	325 mm
Internal capacity	200 ml	200 ml
Net Weight	19 kg	39 kg

## Siting Considerations

All the units are air cooled, air being pulled in through the front and expelled from the rear. The ventilation grilles should never be obstructed, therefore, as this will detract from the performance. Also the fridge units should never be situated in an enclosed space or near an extractor fan, this too will detract from the performance.

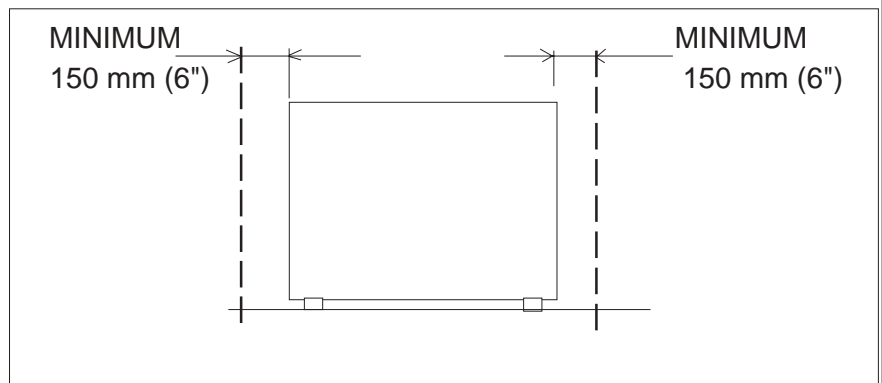

## Setting up the unit

1. Check the voltage marked on the unit's rating plate against that of the mains supply. Connect the mains cable to a suitable plug as in the following table. **Note that the unit must be earthed to ensure proper electrical safety.**

<i>Connections</i>	<i>230V</i>	<i>110/120V</i>
Live	brown	black
Neutral	blue	white
Earth	yellow and green	green

If a fused plug is used it should be fitted with the following value fuse:

<i>Supply</i>	<i>230V</i>
Fuse Rating	13 Amp

Note that units marked 230V on the rating plate work equally well at 220V; units marked 120V on the rating plate work equally well at 110V

**2 Recommended liquids:**

When working at low temperatures always use a liquid suitable for the lowest temperature at which the unit is capable of achieving, see the list of recommended liquids below. When using a flow cooler up to 30°C in an enclosed circuit use the recommended liquid.

For the **RU-500** or **FC-500** units:

<i>Temperature</i>	<i>Liquid</i>
-35 °C to 0 °C *	40% water 40% anti-freeze 20% alcohol

For the **RU-200** or **FC-200** units:

<i>Temperature</i>	<i>Liquid</i>
-20 °C to 30 °C *	50% water 50% anti-freeze.

\* **Warning:** Above 0°C alcohol may evaporate from the liquid giving a health and safety hazard and also deteriorating the mix. Check with health and safety procedures before using above 0°C.

Above 30°C anti-freeze may give off dangerous fumes. Again check with health and safety procedures before using above 30°C.

There is no liquid which will cover the full range of working temperatures. The units are designed to work up to 40°C with occasional peaks to 100°C, see Precautionary Measures in the Operation section. However with the coil removed and a TU-20D or a TU-20C in the bath, the baths themselves are quite capable of going to 250°C.

- 3 Hoses should be as short as possible and secured with clips.
- 4 The whole system should be insulated as much as possible.

**5 DIP COOLERS**

Set up a bath and thermoregulator as described in the operating book for the thermoregulator.

The coil support supplied with the Dip Cooler mounted on a stainless steel plate is used in place of the small cover on the bridge piece of a Techne Bath. Slip the coil support onto the coil and allow it to rest against the end of the flexible. Tighten the knurled black screw on the coil support to prevent the coil moving in the coil support, do not overtighten. Remove the blank cover on the bridge piece and lower the coil through the hole in the bridge. Fix the support securely to the bridge with the two knurled screws previously removed.

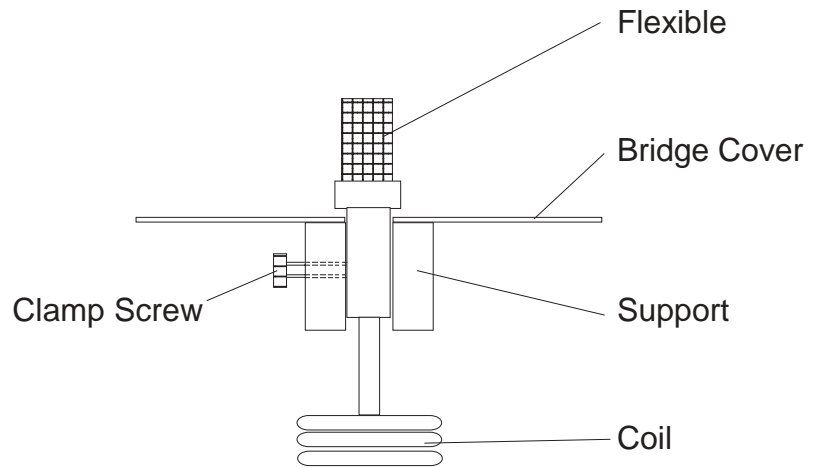

**6 FLOW COOLERS**

Connect the Flow Cooler to a system using 16 mm bore hose which is capable of withstanding both the temperature of operation and the liquid being used. 12 mm bore hose may be used if the hose is soft such as silicone rubber. Ensure the flow is in through the INLET pipe and out through the OUTLET as cooling power will be lost if the flow is reversed.

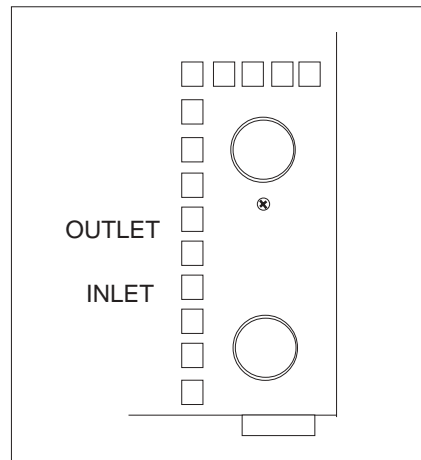

If the system is of a small bore or the viscosity of the liquid prevents the flow being maintained, a by-pass should be incorporated in the system.

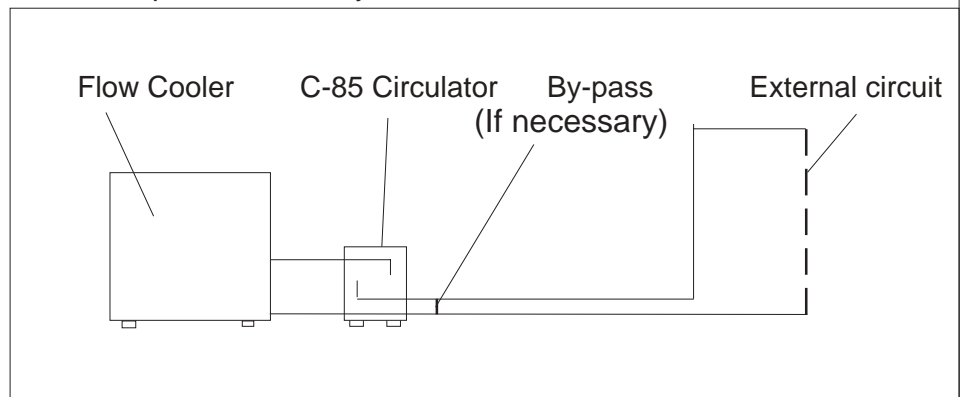

## Carrying a Dip Cooler

A support clip is provided which should be fixed to the side of the unit if it is required to move the unit frequently. It not only makes it easier to carry it also protects the flexible hose. The support clip consists of a block and a long screw. To fit it to the Cooler, remove the screw in the cover at the rear on the opposite corner to the coil, the long screw goes through the block and replaces the screw just removed. There is a lip on the block which should fit over the edge of the cover to give the support stability. The coil is then clipped into the support for ease of carrying.

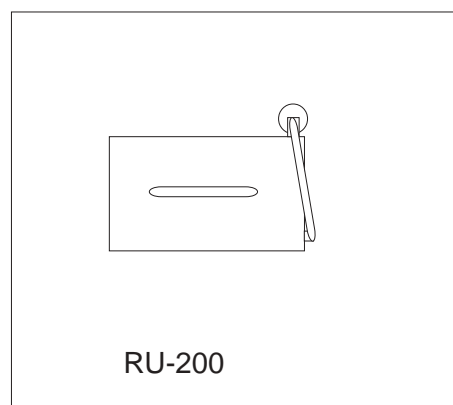
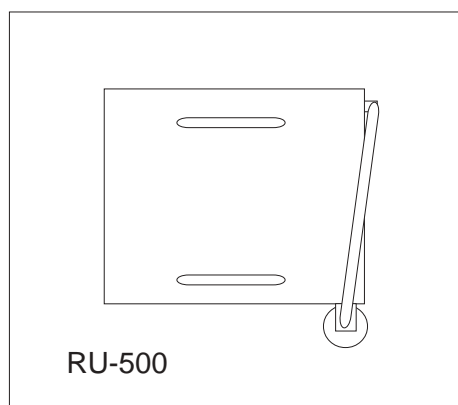

## Cleaning your unit

Before cleaning your unit, disconnect from the power supply and allow to cool to ambient temperature.

You can clean the case of the refrigerated unit with a cloth dipped in water or ethanol (methanol or formaldehyde can also be used). No part of the case or cover should be immersed in the solvents.

Do not use acetone or abrasive cleaners.

## Packing

When you receive your unit, make sure you keep the original packing in case you ever need to return it for service or repair.

The unit must be transported in the original packing to avoid damage. Techne accepts no responsibility for damage incurred unless the unit is correctly packed and transported in this way.



## OPERATION

### Precautionary Measures

- 1 Do not operate any of the fridge units without liquid in the circuit. Ensure that the evaporation coil on the Dip Cooler is covered. Ensure that the heat exchanger in the Flow Cooler is full.
- 2 Freezing may occur if there is insufficient circulation or the incorrect liquid is used. While this will not harm the unit some time may pass before the unit can be used again. For this reason there should always be circulation in or around the coil either in the bath or in the heat exchanger. This is particularly the case for the heat exchanger as the passages are small and it cannot be seen if the unit is frozen. Loss of performance will occur if freezing takes place. Flow through the heat exchanger should be at least 10 litres/min at 20°C.
- 3 To avoid thermal shock do not insert a cold cooling coil into, or fill a cold heat exchanger with, liquids above 40°C.
- 4 Although the practice is not recommended fridge units may occasionally be subjected to temperatures up to 100°C. This is provided that they are only being used thus intermittently, for example for cooling down to temperatures below 40°C.
- 5 IN NO CIRCUMSTANCES MAY A REFRIGERATED UNIT BE SUBJECTED TO BATH/LIQUID TEMPERATURES ABOVE 100°C.
- 6 For continuous use above 40°C either remove the coil from the bath (Dip Coolers) or reconnect the circuit without the heat exchanger in it (Flow Coolers).

### Operating your unit

- 1 Switch on the thermoregulator or circulator as instructed in the appropriate book so that good circulation is established.
- 2 Switch the fridge unit on by pressing the power switch. The switch and the indicator on the front will light up. The fan and the compressor will start. It will take a little while for cooling to begin.
- 3 Remember that as the Fridge units will only extract heat, a controller, such as a TE-10 or TU-20 thermoregulator or C-85 circulator, will need to be incorporated in the system. Temperatures are set on and controlled by the temperature controller, see the appropriate book.

## Daily Maintenance

As mentioned earlier, it is imperative that the air flow is not impeded in any way. It is important that the grilles are kept clean and clear at all times. Even dust and fluff can impair the performance, therefore the units must be used in a clean environment or they should be regularly cleaned.

## Fault Finding

- 1 Check that the airways have not been restricted either by something placed in front of them or through build up of dust and fluff on the grilles, etc.
- 2 Loss of performance is most often caused by deterioration of the working liquid. As a first check always mix up a new batch of liquid and re-test the unit. NEVER top up the mix with water always use a quantity of the proper mix.
- 3 The next most common cause of poor performance is that the liquid is not being circulated over the coil or through the heat exchanger properly. First check that the pump unit is not blocked either by foreign matter or by balls from a ball blanket or in any other way. Also check that the pipe system, if you are using the fridge unit for an external system, is not kinked or restricted in any way.
- 4 If the liquid or the circulation is not the cause of the poor performance then there may be a number of other causes.
- 5 Check that the internal fan is running by feeling if there is air blowing when the unit is on. If not then the unit needs servicing as below.
- 6 Check that the compressor is running by listening for it to start and stop as the unit gets to its lowest temperature. If not then the unit needs servicing as below.
- 7 Last of all the unit may have lost gas and needs servicing as below
- 8 For detailed repair instructions of the thermoregulator refer to the appropriate model instructions.

**NOTE: Before any work is undertaken on the thermoregulator it MUST be removed from the bath.**

## Service

- 1 Complete servicing and repair of Techne products is available at Techne see the contact information on pages 3 or 4.
- 2 A Service Manual is available and servicing may be undertaken by any competent refrigeration engineer.

The following table gives a guide as to the gas charge for each of the units:

<i>Unit</i>	<i>Refrigerant §</i>	<i>Charge *</i>
RU-200	R134a	95 gm
RU-500	R404a	250 gm
FC-200	R134a	95 gm
FC-500	R404a	240 gm

\* There have been several improvements in design which have varied the charge. To increase the cool-down rate increase the charge slightly; to reach a lower temperature reduce the charge slightly. Adjust the charge during testing.

§ Early units were charged with R12 or R502 please consult Techne for advice on repair of older units. Units charged with R404a or R134a have GN after the Serial Number, eg 12345/5 GN.



**205 Westwood Ave**  
**Long Branch, NJ 07740**  
**1-877-742-TEST (8378)**  
**Fax: (732) 222-7088**  
**salesteam@Tequipment.NET**

## ADDITIONAL INFORMATION

Brief fault finding notes and lists of accessories are given in this section.

NOTE THAT THIS EQUIPMENT SHOULD ONLY BE DISMANTLED BY PROPERLY TRAINED PERSONNEL.

**REMOVING THE OUTER COVERS OR BASE EXPOSES POTENTIALLY LETHAL MAINS VOLTAGES AND A FAN.**

THERE ARE NO USER SERVICEABLE PARTS WITHIN THE EQUIPMENT.

## General advice

In the unlikely event that you experience any problems with your refrigerated unit which cannot be easily remedied, you should contact your supplier and return the unit if necessary. Please include any details of the fault observed and remember to return the unit in its original packing. Techne accept no responsibility for damage to units which are not properly packed for shipping: if in doubt, contact your supplier.

## General fault finding

### Fuses

If the power light on the power switch is lit, the fuse may have blown. Make sure there is no external cause (such as a faulty plug or lead).

Fuses should only be changed by suitably qualified personnel. If the fuses blow persistently, a serious fault is indicated and you may need to return the unit to your supplier for repair.

## Accessories

There are many accessories, these are constantly being updated and details can be found in Techne Sales literature. They include:

- Temperature Program Software;
- Cooling Water Pack;
- Refrigeration Control Pack;
- Test Tube Racks;
- and so on.